

Superluminescent Diodes. Application Notes. SLD Sensitivity to Optical Feedback.

Prepared by Vladimir Shidlovski, Superlum, © 2006

Feedback-induced changes in SLD performance.

Feedback vs. optical power, experimental results.

*Design optimization of SLD-based lightsources
from the viewpoint of optical feedback effects.*

www.superlumdiodes.com

Moscow, Russia, Tel. +7-495-799-5179, Fax +7-495-720-5465, e-mail: support@superlum.ie

Introduction

This Application Note deals with some details about SLD sensitivity to optical feedback. This sensitivity is an intrinsic property of SLD devices that occurs due to very high optical gain in the active region and gain saturation phenomena. The more powerful is the SLD the more sensitive it is to optical feedback. General consideration of SLD sensitivity to backreflections is available in “Superluminescent Diodes. Short Overview of Device Operation Principles and Performance Parameters”, www.superlumdiodes.com/pdf/sld_overview.pdf. Below we will discuss this phenomenon in more details basing on results of direct measurements on different SLDs of Superlum. Some consequences, which must be taken into account in design of SLD-based lightsources, will be discussed as well.

Effects of “weak optical feedback”, i.e. such not resulting in latent or catastrophic SLD damage, will be considered.

Feedback-induced changes of SLD performance – experimental results.

Experimental setup is shown on the Fig.1. Polarization controller allowed adjustment of returned signal polarization (investigated SLDs were partially polarized, from 3:1 up to 10:1). Controller was always tuned to get maximum possible SLD “reaction” to returned light, i.e. maximum possible increase of PD monitor photocurrent.

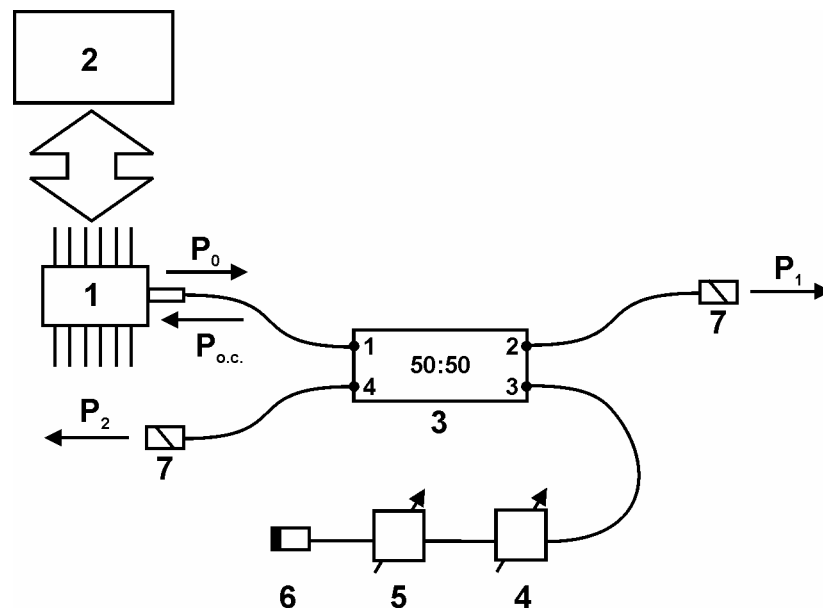

Fig.1. Experimental setup. 1 – SM fiber coupled temperature controlled SLD module with back facet monitor photodiode; 2 – driver, 3 – broadband (750-1000 nm) polarization insensitive 50:50 coupler; 4 – polarization controller, 5 – variable optical attenuator, 6 – fiberoptic mirror, 7 – FC/APC connectors (maximum -55 dB backreflections). Efficiency of optical feedback was measured using P2 output. SLD power was measured from P1 output. All SLDs were supplied in constant current mode controlled by PILOT-4 current and temperature controller www.superlumdiodes.com/pilots.htm.

Following SLDs were used for experiments:

- medium power SM fiber coupled SLD modules SLD-381-MP at 830 nm band, typical output power 2 mW;
- high power SM fiber coupled modules SLD-381-HP, fiber output power up to 30 mW;
- medium (typically 2 mW) and high (> 20 mW) power broadband SM fiber coupled modules SLD-371 at 840 nm.

Standard SLD-381 modules have “bell-like” spectrum at any output power. It shifts with SLD drive current. The shift is determined by two effects: change of carrier density and self-heating of active region by injection current. The first effect tends to decrease SLD wavelength and the second one tends to increase it when SLD current increases. Fig. 2 shows typical dependence of SLD power on drive current and typical optical spectra of SLD-381-HP3 module at different power.

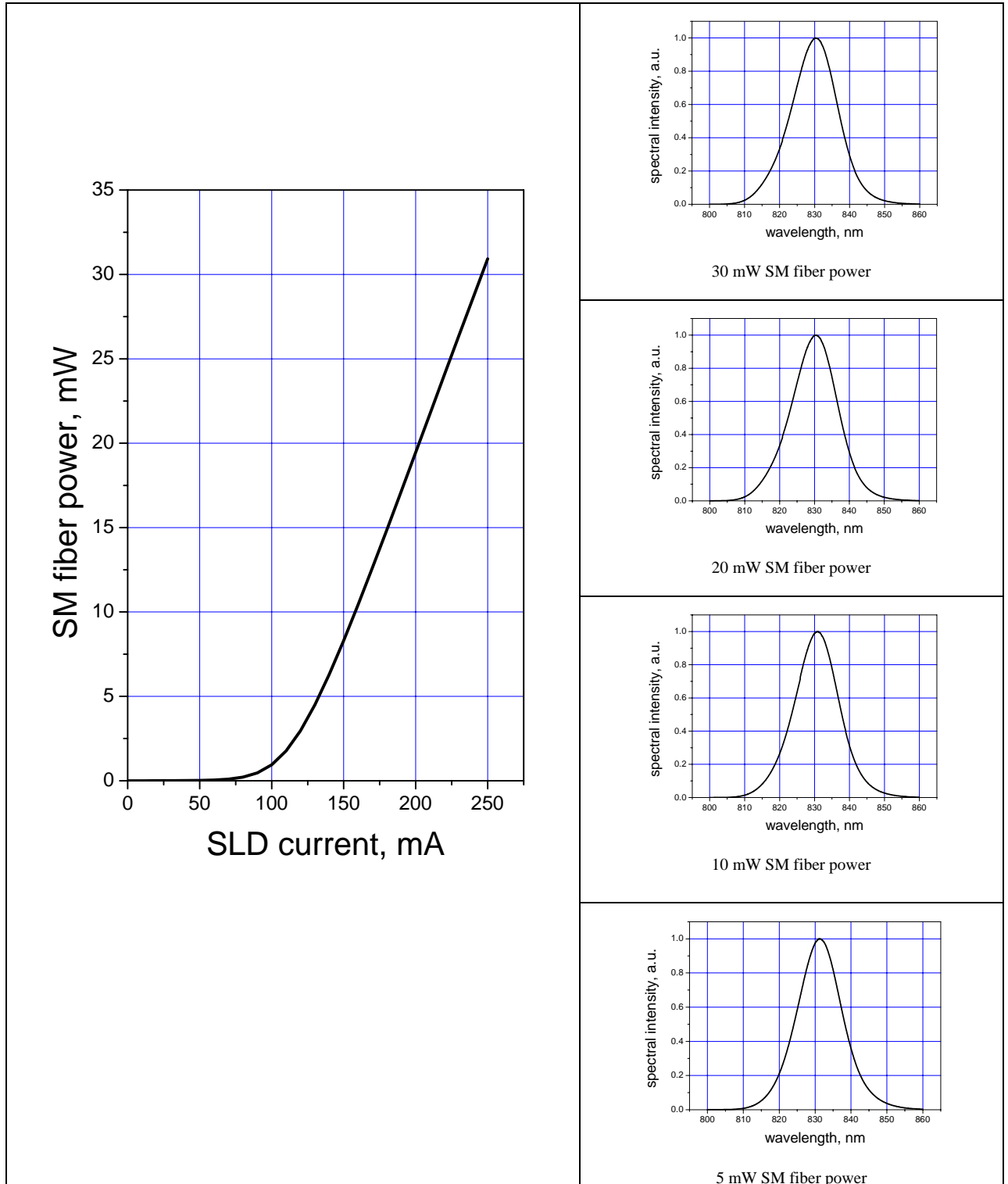

Fig.2. Light-current characteristic and spectra of SLD-381-HP3 SM fiber coupled module centered around 830 nm

SLD-371 is broadband design that allows 50 nm spectrum width at 830 nm band. Its spectrum changes very strongly with drive current and output power, following subbands filling in

quantum well active region by carriers. Typical evolution of SLD-37-HP3 spectrum is shown on the Fig.3.

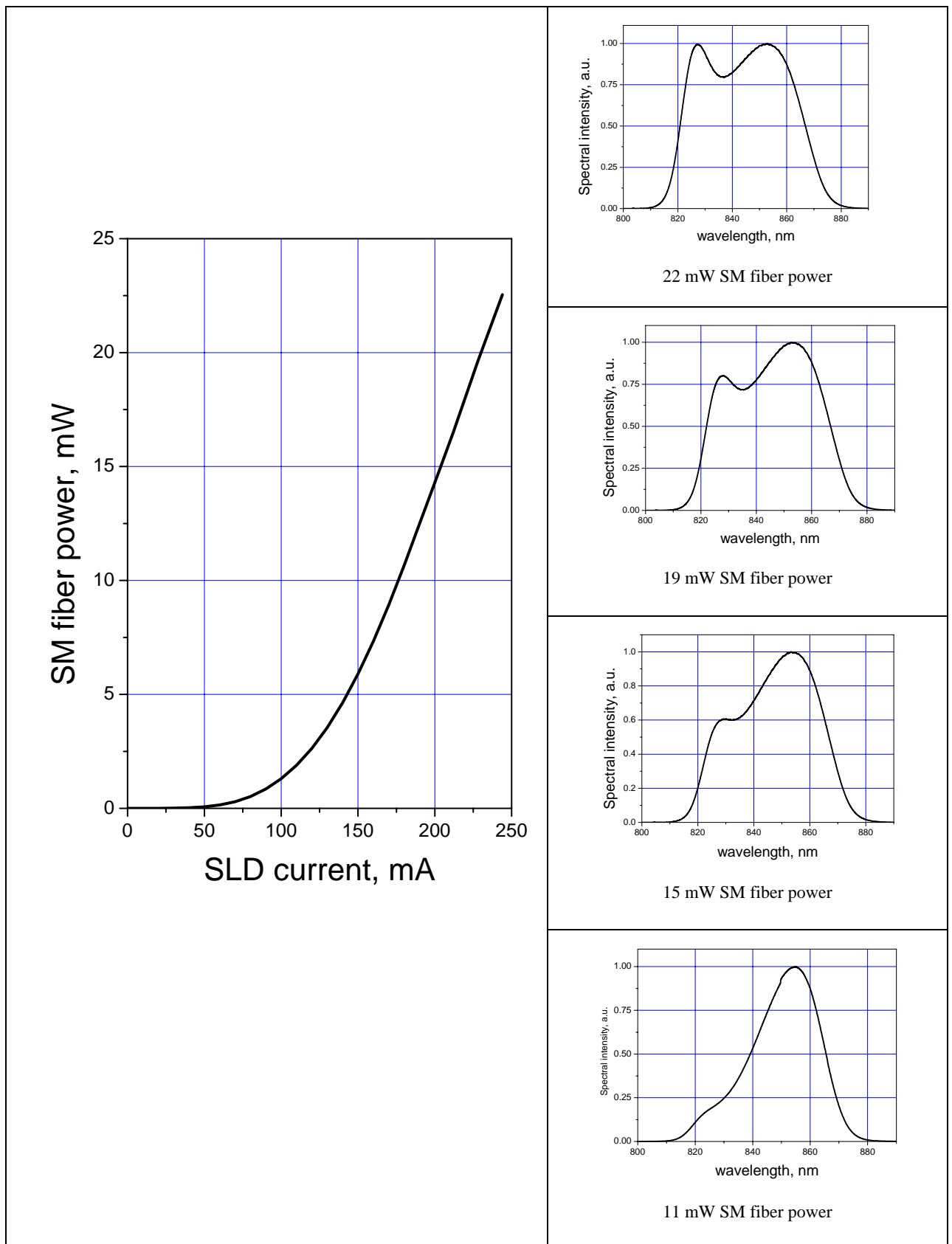

Fig.3. Light-current characteristic and spectra of SLD-371-HP3 SM fiber coupled module

Fig. 4 shows results on measurements of SLD-381 reaction to optical feedback.

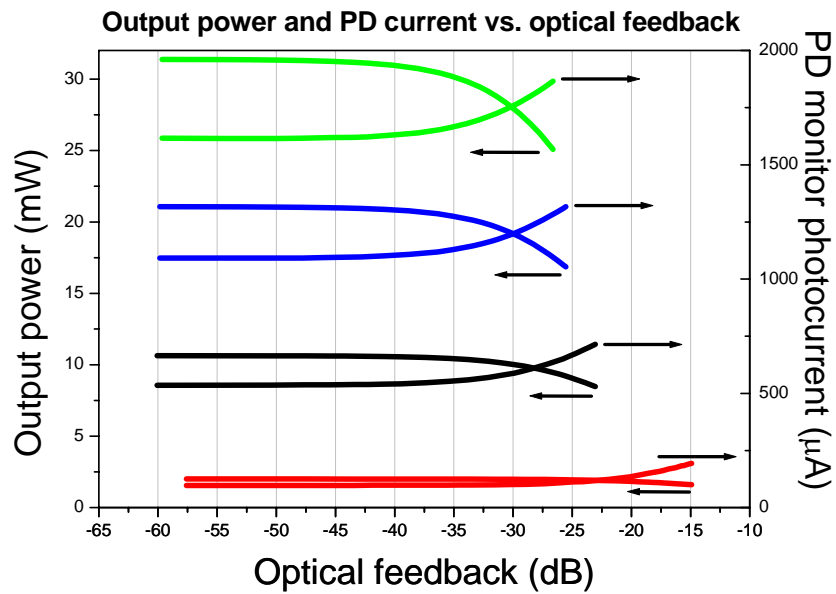

Fig.4. Results on study of SLD-381 reaction to optical feedback. red : SLD-381-MP, black: SLD-381-HP1, blue – SLD-381-HP2, green – SLD-381-HP3.

It is seen that the most powerful 30 mW ex SM fiber SLD-381-HP3 reacts to optical feedback of as low as 10^{-4} . Optical gain in these SLDs is around 30 dB (see “SLD Overview” mentioned above). Coupling efficiency to SM fiber is around 50% in HP-rated SLDs. It means that if 10^{-3} fraction of output power will be returned back to the fiber, it should add some 50% to PD monitor current with respect to its “feedback-free” value. In reality, though, increase of PD monitor current is less because such feedback already saturates optical gain of powerful SLDs. This is why only some 10 – 15% increase of PD monitor current is obtained in HP rated SLD-381 diodes when 10^{-3} optical feedback is applied. Similarly, 10^{-4} feedback shall result in some 5% increase of PD monitor photocurrent in case of 30 dB gain. This coincides well with experimental observations.

As it follows from Fig.4, MP rated SLDs are much less sensitive to optical feedback. This is due to lower optical gain in SLD chip (20 – 25 dB) and lower coupling efficiency to SM fiber (25 – 30%).

No considerable influence of weak optical feedback on SLD-381-HP spectrum had been obtained in our measurements. Particularly, no spectral changes were found in SLD-381-HP3 at -27 dB feedback and in SLD-381-HP1 at -23 dB feedback unless output power has already decreased by 20% with respect to free-running operation. In MP-rated diodes, no considerable spectral changes were obtained up to -15 dB of feedback signal. Measurement tolerance was around 0.1 nm, resolution better than 0.02 nm.

However, essential feedback-induced spectral changes were obtained in broad-spectrum SLD-371. Changes of output power and PD monitor photocurrent (see Fig. 5) were similar to those of SLD-381. Minor differences in “absolute values” of feedback sensitivity (for example: in 371-HP3 power decreased by 20% to initial value at -29 dB feedback; in 381-HP3 the same degradation was obtained at -27 dB feedback) were most probably due to few-dB-different values of optical gain (and saturated gain), which are hard to estimate exactly. But SLD spectrum was strongly influenced by optical feedback. Fig.6 illustrates feedback-induced spectral changes

in 371-HP3. It is seen that 20% power degradation is accompanied by considerable degradation of “short wavelength” spectral maximum.

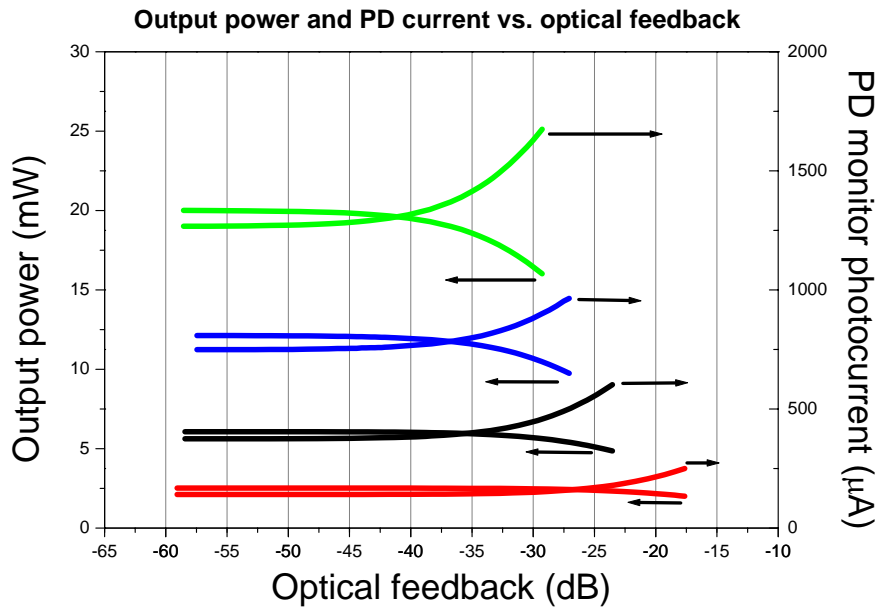

Fig.5. Results on study of SLD-371 reaction to optical feedback. red: SLD-371-MP, black : SLD-371-HP1, blue – SLD-371-HP2, green – SLD-371-HP3.

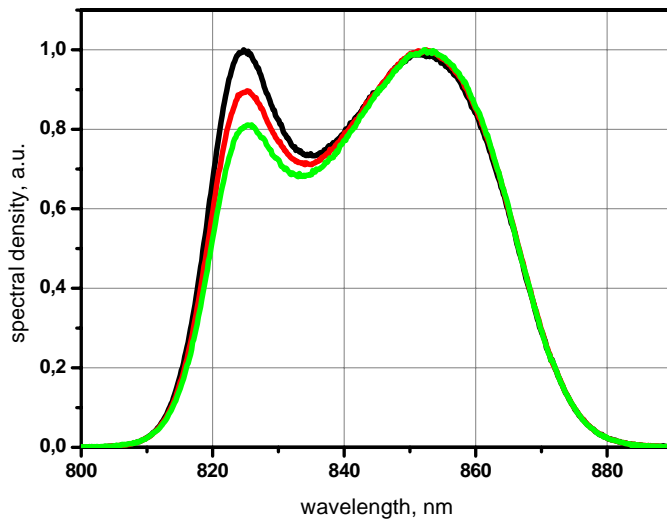

Fig.6. Feedback induced changes in SLD-371-HP3. Black – no feedback, red – -35 dB feedback, green – -29 dB feedback.

Detailed description of physical reasons for obtained results is behind the aim of this Application Note. Let us just summarize the main conclusions, which are important for SLD users:

- A. In powerful SLDs, optical feedback of as low as 10^{-3} already increases back facet power (PD monitor photocurrent) and decrease SLD output power via gain saturation effect, and may be the reason for considerable instability of device;

- B. Relatively weak optical feedback may change SLD spectrum considerably depending on SLD design;
- C. The “measure” of SLD spectrum changes under weak optical feedback may be spectral performance of free-running (i.e. feedback-free) SLD. Small spectral changes are expected in SLDs with weak dependence of SLD spectrum on drive current and output power. Considerable changes should be expected if spectrum of free-running SLD (both SLD wavelength and spectrum width) changes strongly with SLD output power and drive current.

Superlum offers medium power and high power SLDs at different spectral ranges from 680 nm to 1600 nm. Following weak-optical-feedback-induced effects should be expected in these devices:

- SLD-26 (680 nm band) and SLD-56 (1300 nm band) will behave similar to SLD-381. We do not expect strong spectral changes in case of weak optical feedback;
- SLD-47 (940 nm) and SLD-52 (1020 nm) will behave similar to SLD-37;
- SLD-53, SLD-57 and SLD-76 will behave little different to SLD-38: spectrum will remain bell-like but will narrow with respect to feedback operation;
- *There may be differences in absolute values of feedback-induced changes of output power, back facet power (PD monitor current), and emitting spectrum, depending on SLD model. These differences are due to variations of optical gain, saturated gain and coupling efficiency to SM fiber. There is no guarantee that your particular SLD module will behave EXACTLY the same like it is shown on Figs 4-6.*

Design optimization of SLD-based lightsources from the viewpoint of optical feedback effects.

Obviously such a strong sensitivity to optical feedback requires specific measures to assure stable SLD performance without damage. Let us discuss the main principles that must be taken into account in developing of SLD-based lightsources.

Every SLD may be driven either in constant current mode (CC, or ACC, automatic current control) or constant power mode (CP, or APC, automatic power control). In first case, electric current driver stabilizes SLD current. In the second one, SLD power is stabilized via negative feedback loop to SLD current. This is possible either by using built-in back facet PD monitor (that is the simplest but indirect way because back facet power is in no direct relation to output power in SLDs) or by de-coupling of small fraction of SLD output power to external PD monitor (when PD monitor is not possible due to SLD design).

Let us start from guidelines for MP-rated SLD-based lightsources. When optical feedback is below -30 dB, both CC and CP driving modes may be used. If optical feedback may be up to -25 dB, special care must be paid to stability issues especially if SLD operates in CP mode. Results above show that feedback of -25 dB should not decrease SLD power by more than 5% when SLD is supplied in CC mode. However, if it is supplied in CP mode via back facet PD monitor, increasing of PD monitor current caused by optical feedback will decrease SLD current thus “enhancing” feedback-induced power degradation. Total expected degradation will be more than 15% with respect to “feedback-free” output power in this case. If external power monitor is used for CP operation mode, optical feedback will result in increasing of SLD drive current via control loop and uncontrollable increasing of back facet power. This may be the reason for reduced lifetime and fast degradation (depending on real values of feedback). If optical feedback to MP rated SLD may exceed -20 dB, we recommend using of optical isolators.

The results of measurements clearly demonstrated that HP-SLD-based lightsources must be optically isolated if optical feedback in excess of -35...-30 dB is expected from the system. If lower feedback is expected, we would recommend CP driving mode (via PD monitor). This driving mode will protect SLD from “slow occasional feedback”, if such will ever occur. Note this protection works only within bandwidth of CP feedback loop, which is limited by bandwidth of electric feedback loop and PD monitor bandwidth. The last is fundamental limit. Superlum uses different PD monitors in different SLDs. You can always ask about PD monitor bandwidth in each particular type of SLD with internal PD monitor.

If estimations show that optical feedback to HP-SLD-based lightsource may exceed -30 dB, appropriate optical isolator must be used to protect SLD from optical feedback. In this case, we recommend CP driving via PD monitor.

The main conclusions from this short consideration are as follows.

1. CP operating mode via internal PD monitor is recommended for SLD-based lightsources, when possible.
2. Do not use SLD power stabilization by de-coupling of fraction of SLD output power to external monitor. This may result in SLD damage. Use this design ONLY if SLD module, either MP or HP, is followed by optical isolator, or obtain additional study which will 100% prove that optical feedback exceeding -25 dB (MP-rated diodes) and -35 dB (HP rated diodes) will NEVER occur in your system.
3. Use optical isolators if your system is based on HP-rated SLDs of Superlum. Do additional study which will 100% prove that optical feedback will never exceed -30 dB if you want to use HP1 rated diodes of Superlum in your system without optical isolator.
4. Superlum recommend NEVER USE HP2 and HP3-rated diodes in optical systems WITHOUT optical isolators, whatever your estimations and experiments will show. Minor mistake may result in immediate device failure.
5. Note that Superlum’s warranty does not cover SLD damages caused by optical feedback except lightsources with internal optical isolators. Such lightsources always have additional “-I” marking (for example, S-840-B-I-20). Use of any HP-rated SLD without appropriate optical isolator is always at customer’s own risk.

Superlum has outstanding experience in development of SLD and SLD-based lightsources. Since 1995 we offer PILOT drivers www.superlumdiodes.com/pilots.htm. These drivers provide a lot of SLD protection features. For OEM customers, Superlum offers cost-effective OEM “PCB” driver boards.

For those customers who are looking for ready-to-use “plug-and-play” benchtop SLD-based lightsources Superlum offers various “Broadlighters”, from single-SLD based S-series to four-SLD based extremely broadband Q-series with up to 300-nm-wide spectrum. Since October 2006 Superlum offers DC versions of single SLD-based S-series broadband lightsource modules www.superlumdiodes.com/blm_s_series.htm. In the nearest future, miniaturized OEM versions of the most popular D-series Broadlighters at 800-900 nm bands will be available, too.

Would you need specialty product which is not listed among our standard SLDs and SLD-based lightsources, please contact us with your detailed requirements and we will be happy to develop the device which will perfectly fits your needs. Design and manufacturing of SLDs and SLD-based systems is our core business since 1992.